

<THESE INSTRUCTIONS MUST BE GIVEN TO THE END USER>



B&W Trailer Hitches
 1216 Hawaii Rd / PO Box 186
 Humboldt, KS 66748
 P: 620.473.3664
 F: 620.473.3766

Call or Email us for
 Installation Support
 hitches@turnoverball.com
 www.turnoverball.com

Custom 5th Wheel Hitch Mounting Rail Installation Instructions

MODEL 2501

See Limited Lifetime Warranty at
turnoverball.com/warranty

2011-2015 Chevrolet/GMC 3/4 & 1 Ton HD Long & Short Bed Trucks

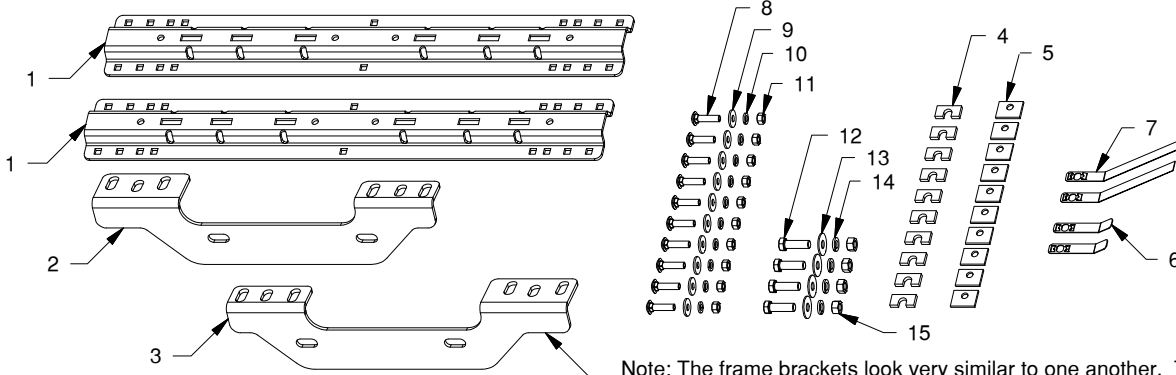

Note: The frame brackets look very similar to one another. This longer bracket feature, indicated here, will be towards the rear of the truck when installed properly.

PARTS LIST			PARTS LIST		
ITEM	QTY	DESCRIPTION	ITEM	QTY	DESCRIPTION
1	2	Mounting Rail (Separate Box)	9	10	1/2" Flat Washer
2	1	Frame bracket, Passenger	10	10	1/2" Split Lockwasher
3	1	frame bracket, Driver	11	10	1/2" Finish Nut
4	10	5/16" U-Shaped Spacer	12	4	5/8" X 2" Hex Cap Screw
5	10	Offset Rectangle Washer	13	4	5/8" Flat Washer
6	2	Front Bolt Guide	14	4	5/8" Split Lockwasher
7	2	Rear Bolt Guide	15	4	5/8" Finish Nut
8	10	1/2" X 2" Carriage Bolt			

⚠ WARNING

Failure to comply with the safety information in these instructions could result in serious injury or death.

- ⚠ Read all installation and operating instructions along with all labels before using this product.
- ⚠ Without proper knowledge, towing can be a dangerous activity. Understand all the risks involved with towing before proceeding. For information on towing safety, see **"The Trailer Handbook: A guide to Understanding Trailer and Towing Safety"** from the National Association of Trailer Manufacturers, www.NATM.com.
- ⚠ This product was designed to fit vehicles in their original, "as manufactured" condition. Compatibility with vehicles having replacement parts, or other modifications is not guaranteed. Inspect vehicle for modifications before installation of this product.
- ⚠ Do not modify this product in any manner. Doing so could alter its integrity and lead to a loss of attachment between the trailer and the tow vehicle.
- ⚠ Do not exceed tow or tongue rating of coupler, tow or tongue rating of hitch, or tow or weight ratings of truck or trailer. See vehicle and trailer manufacturer information for ratings. Exceeding these ratings may cause damage to towing components or loss of attachment between the trailer and truck.
- ⚠ Adding components to the chassis of any vehicle can be hazardous. There is potential for unexpected combustion of fuel, electric shock, burns, shifting or falling of unstable vehicle, damage to vehicle, injury from tool usage and many other hazards. This installation must be completed by someone who is aware of the hazards involved. This person must be knowledgeable of proper safety procedures for a vehicle modification of this nature and for usage of the equipment required to perform the installation.

PREPARING TO INSTALL

NOTICE: If truck is equipped with a removable bed liner or mat, it should be removed or it must be cut to allow the mounting rails to connect directly with the bed. It is acceptable to install the mounting rails over a spray in bed liner.

NOTE: Remove all parts from the packaging and familiarize yourself with all the parts and tools required. Use the parts list on the front page to verify that all parts and hardware are present.

Installation of the mounting rails requires several common tools and a few specialized tools. Below is a listing of equipment used during a typical installation.

- Impact wrench or ratchet with 15/16" & 3/4" sockets
- 15/16" and 3/4" box end wrench
- A drill and 1/8" & 9/16" Drill bits
- Patriot 5th wheel or Slider Base
- Hammer
- Flashlight
- Tape Measure
- Eye Protection
- Ear Protection
- Torque Wrench
- Center Punch Tool

DRILL REAR MOUNTING HOLES

- 1. Layout the rear mounting rail.** Place a mounting rail onto the bed of the truck. Hook a tape measure over the rear edge of the bed (not on any part of the tailgate), measure the location for the mounting rail as shown in figure A1. Next, center the mounting rail in the bed by measuring the distance on either side from the edge of the rail to the sides of the bed. The rail will be centered when both measurements on either side of the rail are the same.

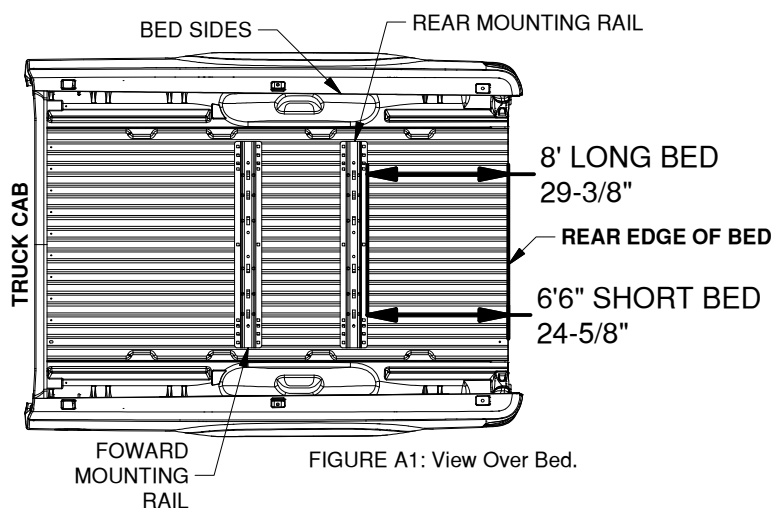

IMPORTANT: The mounting rail is designed to install only at the described location. Failure to place the mounting rail precisely may result in added difficulty during installation and/or property damage.

- 2. Mark hole locations:** While carefully ensuring the mounting rail does not move, use a center punch tool to mark the 5 drill locations on the rear rail. See figure A2 for hole marking locations for this installation (forward rails will install on a later step). Once all 5 rear rail locations are clearly marked, move the bed rail out of the way and drill each location with an 1/8" drill.

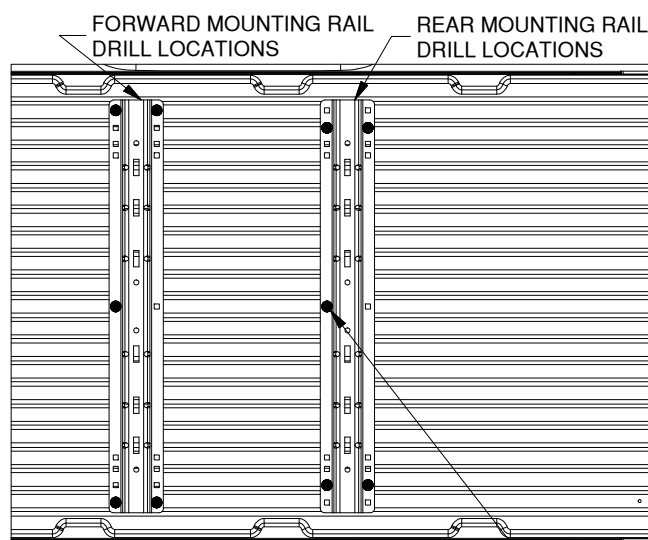

Figure A2: Detail view over bed, showing drill locations for the forward and rear bed rails.

- ⚠ The fuel tank of the truck may be directly below the area of the bed which needs to be drilled. Always carefully examine the area under the truck where drilling will occur before drilling. Make certain that the tank, or other equipment, is not damaged during drilling. Damage to the tank may result in property damage, serious injury or death.**

- 3. Check hole locations:** Using the frame brackets, align each bracket to the side of the frame where the brackets will be installed, see figures A3 & A4. Check that the 1/8" holes are centered within the slots in the frame brackets. If the 1/8" drilled holes are not centered re-drill the 1/8" holes until the brackets and the drilled holes are aligned.

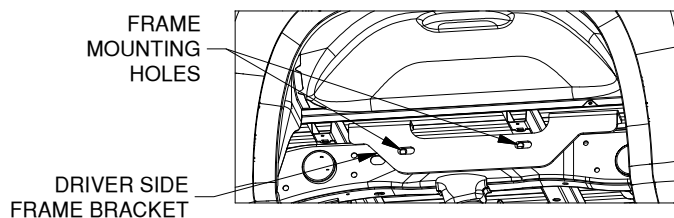

Figure A3: View looking into driver side wheel well.

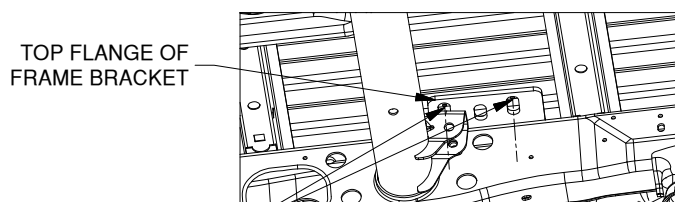

Figure A4: View under bed looking up at drilled area and mounting bracket.

- 4. Enlarge the holes.** Use the 1/8" holes as pilots, drill out each hole with a 9/16" bit.

INSTALL FRAME BRACKETS

- 1. Assemble bolt guides.** Assemble the bolt guides by threading a 5/8" bolt onto each guide as shown in figure B1 and B2. Tighten the bolt onto the guide so that the shoulder of the bolt head is flush with the surface of the bolt guide. This is designed to be a tight fit. A wrench may be needed to thread the bolts onto the bolt guides. The notches of the bolt guides must engage the corners of the bolt head so that the bolt is prevented from "backing off" of the guide. The notches of the bolt guide may have to be pried up if they were smashed down when the bolt was tightened down.

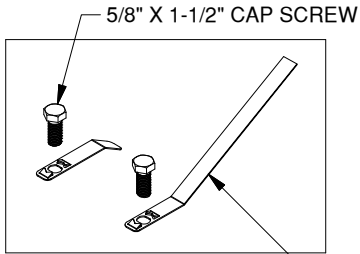

Figure B1: Bolt Guides

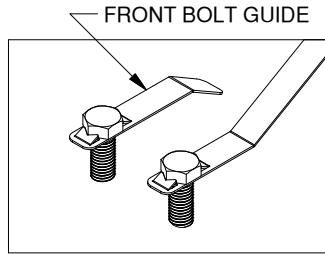

Figure B2: Bolt Guides

REAR BOLT GUIDE

- 2. Install the bolt guides.** Insert the front bolt guides (shorter ones) into the frame and guide the threaded end of the bolts out the holes as shown in figures B3 to B5. Insert the rear bolt guides through the large holes on the inside of the frame rails and guide the threaded end of the bolts out of the holes in the frame as shown in figures B6 to B8.

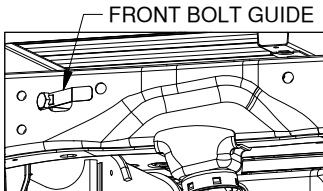

Figure B3: View from outside of driver side wheel well, front bolt guide installation step. 1

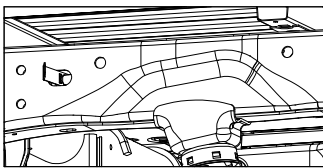

Figure B4: View from outside of driver side wheel well, front bolt guide installation step. 2

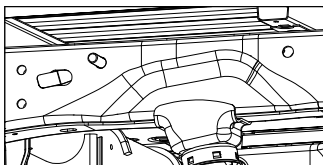

Figure B5: View from outside of driver side wheel well, front bolt guide installation step. 3

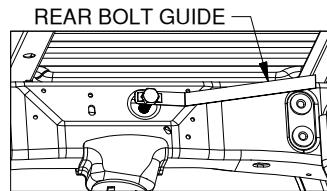

Figure B6: View under bed inside of driver side frame, rear bolt guide installation step. 1

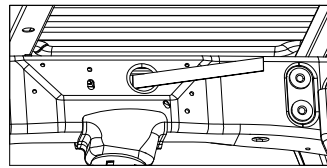

Figure B7: View under bed inside of driver side frame, rear bolt guide installation step. 2

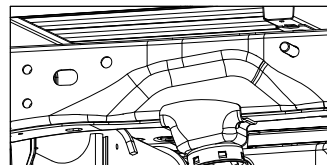

Figure B8: View from outside of driver side wheel well, rear bolt guide installation step. 3

- 3. Install the frame brackets.** Place each frame bracket onto the 5/8" bolts held in place by the bolt guides, see figure B9. Attach the frame brackets to the frame with a flat washer, lock washer, and nut, see figure B10. Do not tighten the mounting hardware at this time.

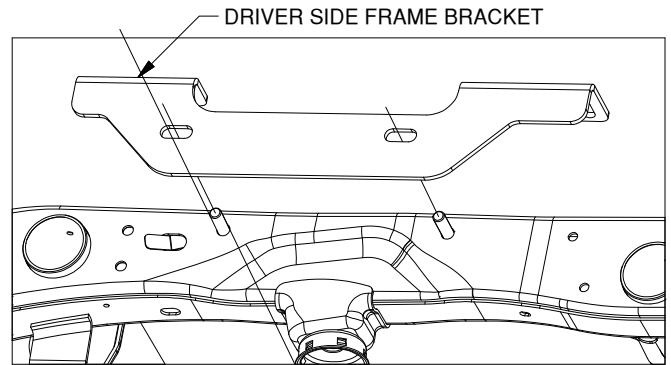

Figure B9: View from outside of driver side frame.

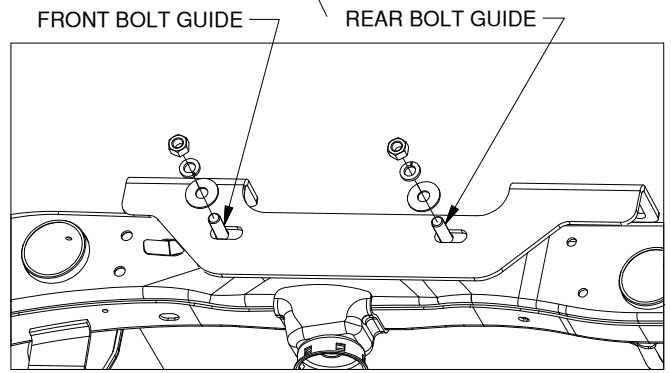

Figure B10: View from outside of driver side frame.

INSTALL REAR MOUNTING RAIL

- 1a. Install the rear mounting rail.** Re-position the rear mounting rail over the drilled 9/16" holes in the bed. Install a 1/2" Carriage bolt through the mounting rail into each of the five drilled holes, as shown in figure C1.

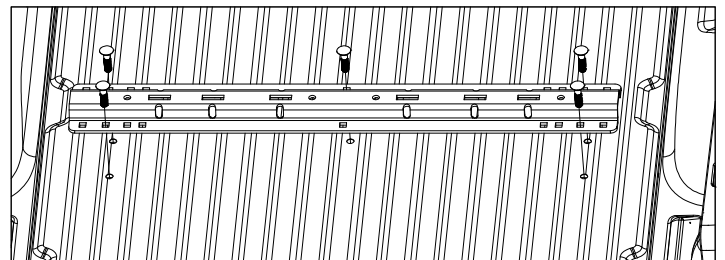

Figure C1: View looking into truck bed from rear of truck.

- 1b. Install the rear mounting rail, cont.** Under the bed install an offset square washer, 1/2" flat washers, 1/2" lock washers and 1/2" finish nuts on each of the carriage bolts, see figure C2. Place the u-shaped spacers, see note below. Hand tighten each nut.

NOTICE: Due to the corrugation in the truck bed, U-shaped spacers are provided to function as space fillers between the mounting rails and the kit attachment hardware. Always place a u-shaped spacer in the gap either above the bed (between the mounting rail and the bed) or below the bed (between the bed and the side mounting brackets). Failure to use u-shaped spacers will result in property damage when hardware is tightened.

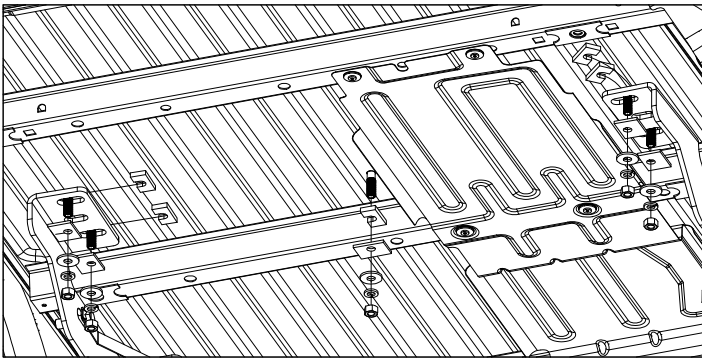

Figure C2: View under bed looking up toward cab. (Frame not shown)

- 2. Position the forward mounting rail.** For this step the base which will be used in the mounting rails is required. Place a mounting rail into the truck bed in front of the rear mounting rail. Place the base over the rail attachment points and carefully lower it until the pin tabs pass through the attachment points on the rear mounting rail. Attach the forward mounting rail to the forward mounting points on the base. The base should rest flat against the top of the rails, See figure C3. With the base still attached ensure that the forward rail is centered in the truck bed.

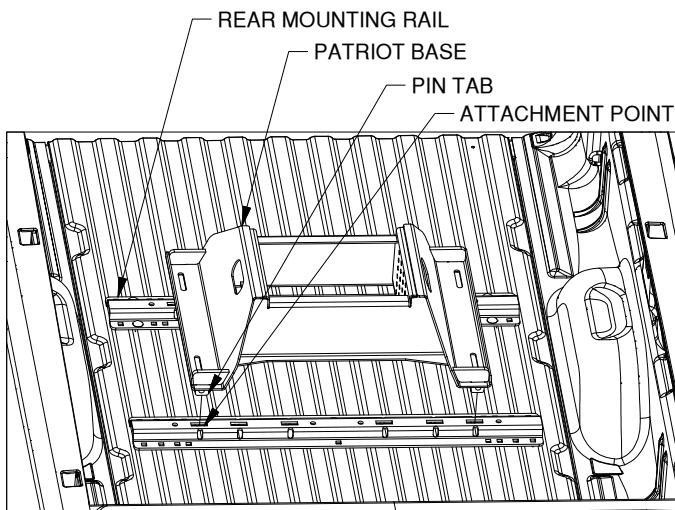

Figure C3: View into truckbed looking back at tailgate.

- 3. Drill forward mounting holes.** Using the same methods as used for the rear mounting rail, mark, drill, check, and enlarge the holes for the forward mounting rail. Refer to "DRILL REAR MOUNTING HOLES" section, steps 2 through 4, on a previous page. Notice that the hole locations are slightly different than the rear rail, see figure A2 (on the second page).
- 4. Install forward mounting rail.** Refer to the "INSTALL REAR MOUNTING RAIL" section, step 1A and 1B, and install the forward mounting rail. Notice that the u-shaped spacer placement is different. See figures C4 and C5.

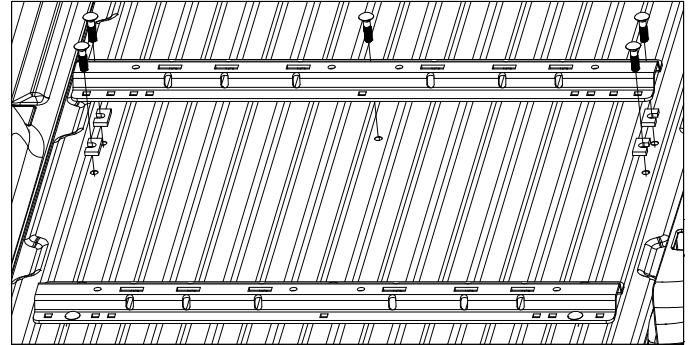
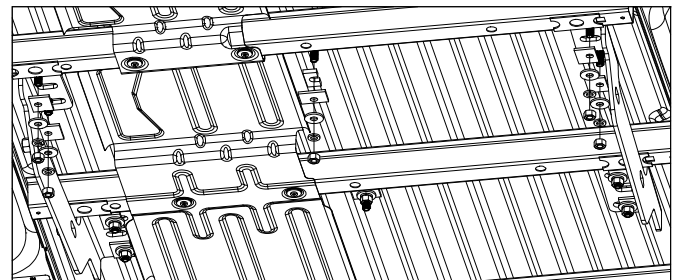

Figure C4: View looking into truck bed from rear of truck.



View C5: View under bed looking up toward the rear of the truck. (Frame not shown)

- 5. Tighten hardware.** Using a torque wrench, first torque all the 1/2" nuts in the mounting rails to 80 ft-lbs. Second torque all the all 5/8" nuts in the frame brackets to 100 ft-lbs.